

TACHOMETER SIGNAL WIRE CONNECTION DIAGRAMS

2650-2182-77



QUESTIONS:

If after completely reading these instructions you have questions regarding the operation or installation of your instrument(s), please contact AutoMeter Technical Service at **866-248-6357**. You may also email us at service@autometer.com.

Additional information can also be found at http://www.autometer.com/tech_faq.aspx

Standard or Electronic with external coil (no ignition box)

Connect the tachometer signal wire to the negative (-) terminal of the ignition coil.

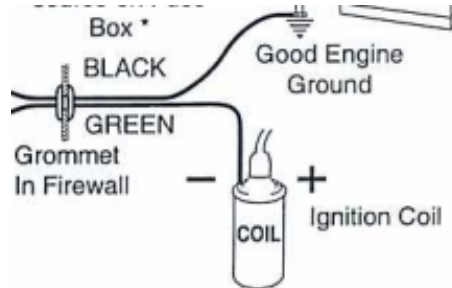

GM HEI Distributor, Internal Coil (with no ignition box)

For the more-common large cap HEI with integral coil, connect your tachometer signal wire to the TACH terminal.

See Photos Below showing the green wire connected to the TACH Terminal.

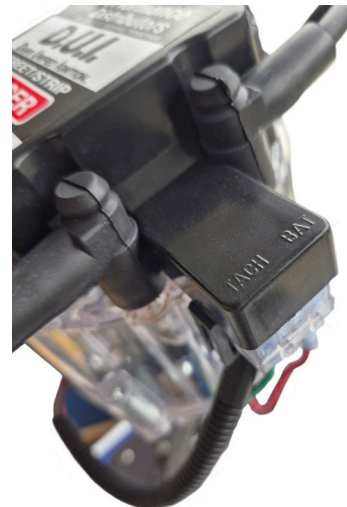
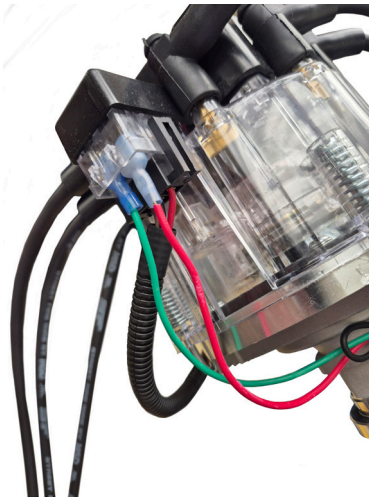

GM HEI Distributor, External Coil (with no ignition box)

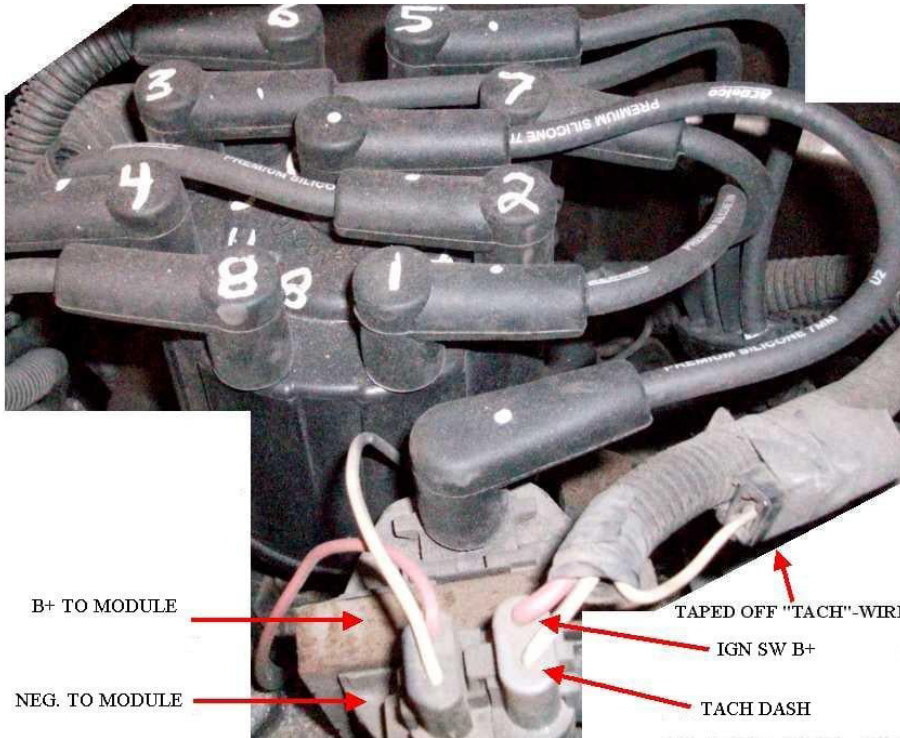

For the later GM EXTERNAL coil HEI, locate the white wire of the gray ignition coil connector at the externally mounted coil and connect your tachometer signal wire to the white wire.

NOTE: Not all applications will have the taped up Tach Wire that is shown in the image.

Chrysler/Mopar Electronic with Chrysler external ignition module

If connecting to the ignition coil causes tachometer reading issues, or jumpiness, move your tachometer signal wire to the gray wire of the Chrysler ignition module. You might even choose to simply connect there to begin with.

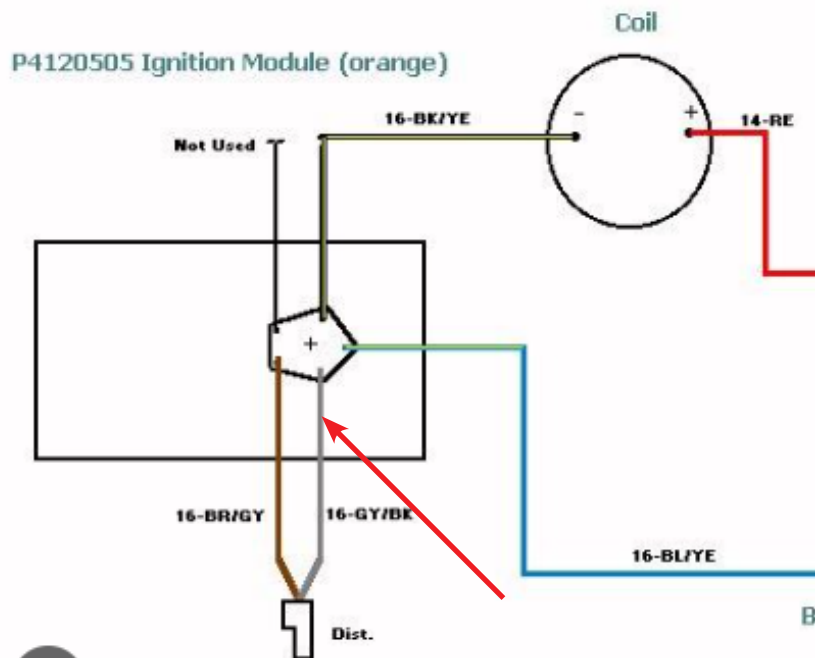

Ford Duraspark Electronic Ignition (with external Duraspark box/module)

If connecting to the ignition coil causes tachometer reading issues, or jumpiness, move your tachometer signal wire to the orange wire of the Duraspark ignition module. You might even choose to simply connect there to begin with. Green tachometer wire connected to the Orange Duraspark Module wire, shown below

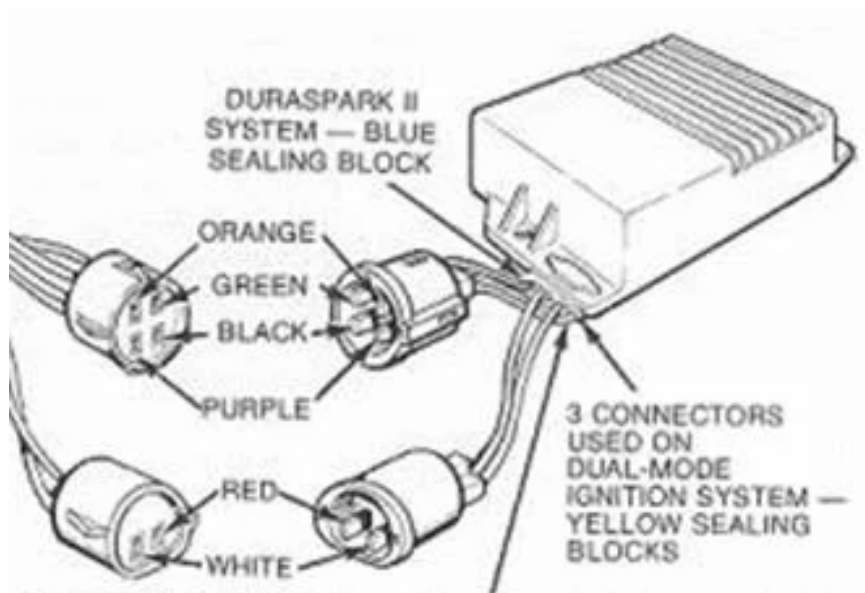

Ford TFI equipped (Dist mounted module, external coil)

In Most cases, the Ford TFI module equipped vehicles will use a green, or dark green with yellow trace wire at the ignition coil. You may connect your tachometer to this wire. *Quick tip on Ford coils with the rectangular plug-in wire connector, if you unplug the connector, many times inside the connector cavity of the coil, there will be a + & - marking pertaining to terminal position.

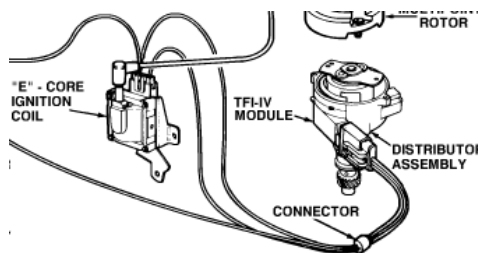

After Market “Stand Alone” or “Ready to Run” Electronic distributors (with no ignition box)

Many after market distributors have a separate tachometer signal wire. If they do, then use it. If they do NOT have a separate tachometer signal wire, and no ignition box, you may connect to the negative (-) side of the ignition coil (image shows an MSD distributor with a separate tachometer wire).

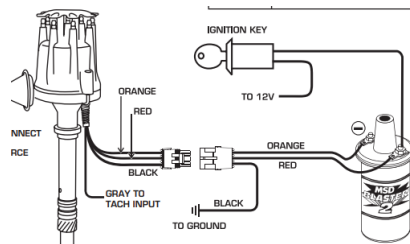

Any OEM or After Market distributor WITH an after market ignition box

ANY TIME you are using an after market ignition box, carefully research their instructions. MOST will have a separate tachometer signal wire or port, and this MUST be used. If connection is made to the coil in this case, permanent damage to the tachometer can happen, and warranty void. After CAREFUL research, if no terminal, port or wire is supplied by the box manufacturer, you may then contact us for recommendations to make sure your tachometer is not damaged by improper hook up.



(older) Honda Distributor Equipped Electronic Ignition

13. Right Side of Engine

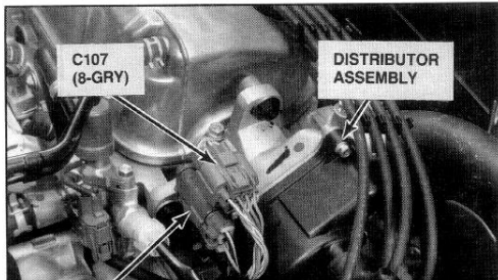

Locate the distributor, and at the (2-wire) connector, one of those wires will be solid blue (no stripe). This will provide a good, 4cylinder, 2-pulse tachometer signal.

Holley Terminator

Holley provides a useable tachometer signal from a blue wire with a white stripe. This wire is not terminated into a connector from Holley.

271R968A LS1 MAIN HARNESS (HARNESS ONLY SALES P/N 558-102)

DESCRIPTION	COLOR	WIRE GAUGE	PIN #
COIL-IN	YELLOW	22 ga	A1
FUEL PUMP RELAY OUT (10A MAX)	RED	22 ga	A2
INPUT #2 (F,5,2,T,H,G)	WHITE/RED	22 ga	A3
INPUT #4 (F,G,5)	WHITE/GREEN	22 ga	A4
TPS SIGNAL	GREEN	20 ga	A5
POINTS OUTPUT	WHITE	18 ga	A6
WBI_COMPR2	TAN	20 ga	A7
WBI SHIELD	SHIELD	20 ga	A8
WBI HTR -	YELLOW	18 ga	A9
SWITCHED +12V IN	RED/WHITE	20 ga	A10
MAT INPUT	BLUE	22 ga	A11
INPUT #1 (F,5,2,T,H,G)	WHITE/BLUE	22 ga	A12
INPUT #3 (F,G,5)	WHITE/BLACK	22 ga	A13
IPU GROUND	BLACK/SHIELD	22 ga	A14
DGI TX	WHITE/BLACK	22 ga	A15
WBI COMPR1	BROWN	20 ga	A16
WBI VS-/IP -	BLACK	20 ga	A17
SENSOR GROUND OUT	BLACK/WHITE	22 ga	A18
COOLANT TEMP IN	BROWN	22 ga	A19
OIL PRESSURE	GREY	22 ga	A20
KNOCK #2 IN	BEIGE/RED	22 ga	A21
CAM INPUT (DIG & IPU)	PURPLE	22 ga	A22
MAP SENSOR SIGNAL	RED/BLACK	22 ga	A23
CAN LO	ORANGE	22 ga	A24
WBI VS+	RED	20 ga	A25
SENSOR +5V REF OUT	ORANGE	22 ga	A26
BYPASS OUT	BEIGE/BLACK	22 ga	A27
TACHOMETER	BLUE/WHITE	22 ga	A28
KNOCK #1 INPUT	BEIGE/BLUE	22 ga	A29
CRANK INPUT (DIG & IPU)	PURPLE	22 ga	A30
FUEL PRESSURE	PURPLE	22 ga	A31
CAN HI	ORANGE/BLACK	22 ga	A32
WBI IP+	WHITE	20 ga	A33
WBI HTR+	ORANGE	18 ga	A34

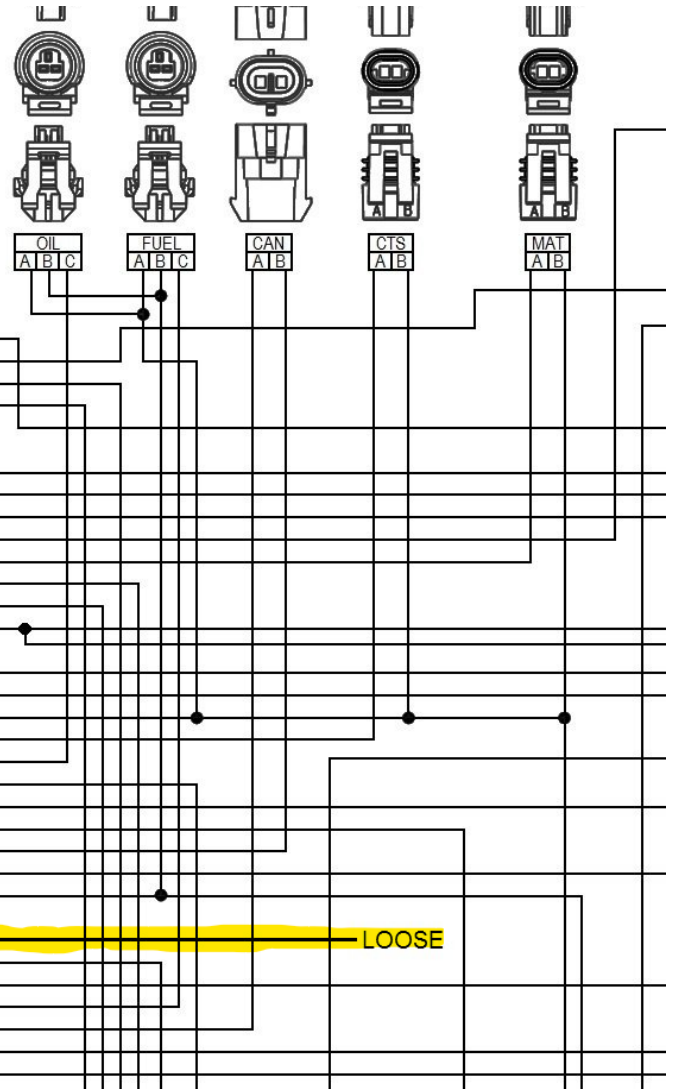

Early GM V6 Coil Pack Ignitions

GM Coil Pack ignitions from the mid 80's to the mid 90's, with a single connector, look for pin E. This wire will provide a useable tachometer signal. See image to the below. (Do NOT connect to the white wire at pin A!)



GM Ignition coil pack ignitions with 3 connectors (2 at one end, one at the other), locate a white wire at pin C at the larger connector shown to the right. This will provide a usable tachometer signal. If this spot is unpopulated (pin C has nothing there), there your next option will be to use an Auto Meter 9117 Tachometer Adapter.

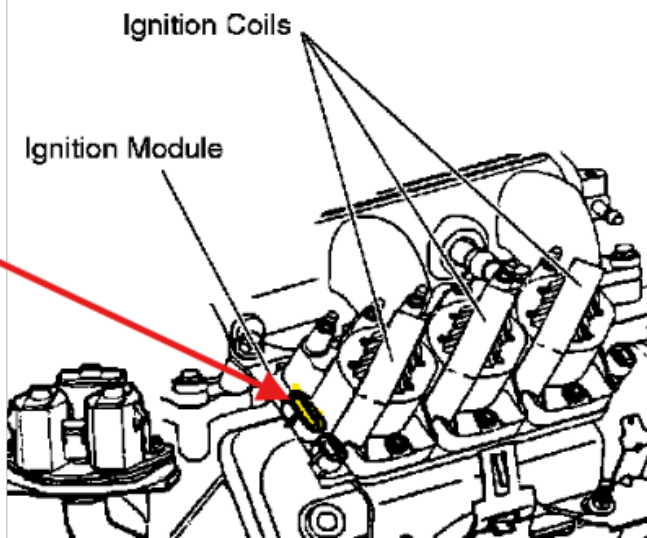

Coil Pack and Coil-on-Plug ignitions when no tachometer signal is available from a module or computer.

Some applications WILL have an available signal, though some do not. Check with our Tech Support Team for verification on your specific application if needed.

The 9117 is a Current-Sensitive device. Therefore the power for all ignition coils must be "broken/cut" at some point, cutting the power to all coils. The 9117 wires in between these cut halves, thus re-powering the coils. See general samples below.



Original Power to the coils

Correct Installation

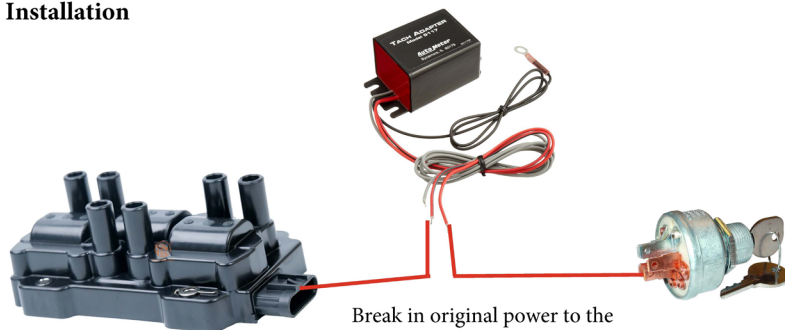

Break in original power to the coils. solid red of 9117 on the ignition switch/power-side. Red/Green of the 9117 connects to the coils-side, thus completing the circuit.

Incorrect Installation

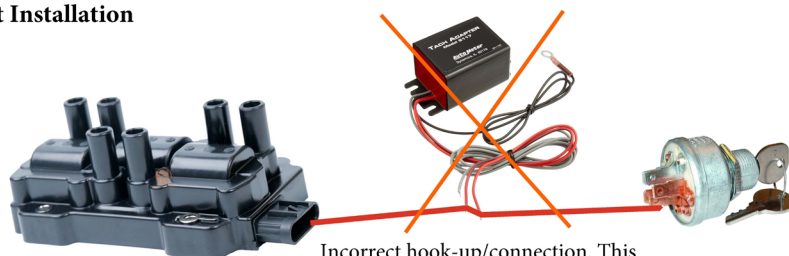

Incorrect hook-up/connection. This will not allow the adapter to work by simply splicing onto the original power. There MUST be a break in the original power for the 9117 to function properly.

Tachometer Filter model 9116

The tach filter is used for applications where you may be experiencing poor behavior of the tachometer pointer (ex: bouncing/spiking/jumpiness) due to an electrically noisy ignition system. This may help with your situation. The tachometer filter has a more complex circuit, more than a simple in-line resistor which is commonly used.



Filtering a Tachometer Signal with a simple resistor.

Sometimes if the tachometer signal is a little "spikey" or jumpy, you can correct it by adding some resistance to the signal input wire going to the tachometer. Cut your signal wire in half and solder, or crimp the resistor in between the two cut halves.

We recommend a 10k (10,000 ohm) ½ watt resistor. A ¼ watt can be used. We recommend ½ simply due to being more robust for handling.

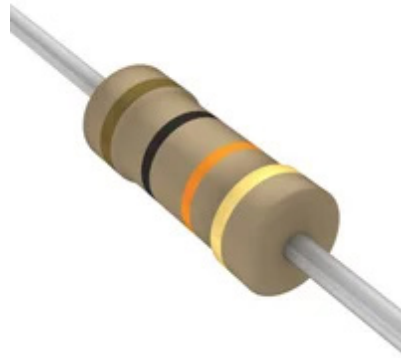

FOR SERVICE SEND TO: **AUTO METER PRODUCTS, INC.** 413 W. Elm St., Sycamore, IL 60178 USA

USA (866) 248-6357

International: (815) 895-8141

Email us at service@autometer.com

<http://www.autometer.com>